

BUNKER PRO User Manual

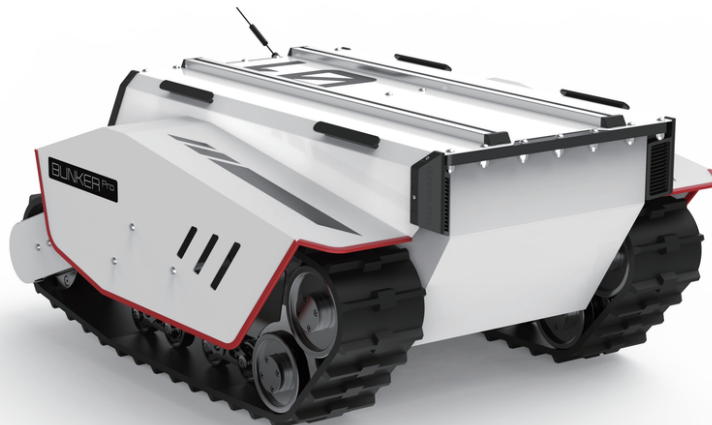

BUNKER PRO

AgileX Robotics Team

User Manual V.2.0.1 2023.09

Document version

No.	Version	Date	Edited by	Reviewer	Notes
1	V1.0.0	2023/3/17	谢瑞亲		first draft
2	V2.0.0	2023/09/02	谢瑞亲		Add rendering image Modify how to use ROS package Document checking

3	V2.0.1	2023/09/018	吴忠义	Synchronized car parameter list Added table 3.2 Fault information description table
---	--------	-------------	-----	---

This chapter contains important safety information, before the robot is powered on for the first time, any person or organization must read and understand this information before using the device. If you have any questions about use, please contact us at support@agilex.ai. Please followed and implement all assembly instructions and guidelines in the chapters of this manual, which is very important. Particular attention should be paid to the text related to the warning signs.

Important Safety Information

The information in this manual does not include the design, installation and operation of a complete robot application, nor does it include all peripherals that may affect the safety of this complete system. The design and use of the complete system need to comply with the safety requirements established in the standards and regulations of the country where the robot is installed.

The integrators and end customers of BUNKERPRO have the responsibility to ensure compliance with relevant provisions and practical laws and regulations, and to ensure that there are no major hazards in the complete application of the robot.

This includes but is not limited to the following:

Effectiveness and responsibility

- Make a risk assessment of the complete robot system.
- Connect the additional safety equipment of other machinery defined by the risk assessment together.
- Confirm that the design and installation of the entire robot system's peripherals, including software and hardware systems, are correct.

- This robot does not have the relevant safety functions of a complete autonomous mobile robot, including but not limited to automatic anti-collision, anti-falling, creature approach warning, etc. Relevant functions require integrators and end customers to conduct safety assessment in accordance with relevant provisions and applicable laws and regulations to ensure that the developed robot is free of any major hazards and hidden dangers in practical application.
- Collect all the documents in the technical file: including risk assessment and this manual.
- Know the possible safety risks before operating and using the equipment.

Environment

- For the first use, please read this manual carefully to understand the basic operation content and operation specifications.
- Choose a relatively open area for remote control, because the vehicle itself does not have any automatic obstacle avoidance sensors.
- Use in an ambient temperature of -20°C-60°C.
- If the vehicle does not individually customize the IP protection level, its water-proof and dust-proof capacity is IP66.

Check

- Ensure that each equipment has enough charge.
- Ensure that the vehicle has no obvious abnormalities.
- Check if the battery of the remote control has enough charge.
- Make sure that the emergency stop switch has been released when using.

Operation

- Ensure that the surrounding area is relatively open during operation.
- Remote control within the line of sight.
- The maximum load of BUNKERPRO is 120KG. When in use, ensure that the payload does not exceed 120KG.
- When installing an external extension for BUNKERPRO, confirm the center of mass of the extension and make sure it is at the center of rotation.
- When the equipment's voltage is lower than 48V, please charge it in time.
- When the equipment is abnormal, please stop using it immediately to avoid secondary damage.
- When the equipment is abnormal, please contact the relevant technical personnel and do not handle it without authorization.

- Please use it in an environment that meets the requirements of the protection level according to the IP protection level of the equipment.
- Do not push the vehicle directly.
- When charging, make sure that the ambient temperature is greater than 0°C.

Maintenance

- Regularly check the tension of the suspended track, and tighten the track every 150~200H.
- After every 500 hours of operation, check the bolts and nuts of each part of the body. Tighten them immediately if they are loose.
- In order to ensure the storage capacity of the battery, the battery should be stored with charge, and the battery should be charged regularly if it is not used for a long time.

Attention

This section contains some precautions for using and developing BUNKERPRO.

Battery precautions

- When BUNKERPRO leaves the factory, the battery is not fully charged. The specific battery power can be displayed through the voltage display meter on the BUNKERPRO chassis rear or read through the CAN bus communication interface;
- Please do not charge the battery after its power is exhausted. Please charge it in time when the low voltage at the BUNKERPRO rear is lower than 48V;
- Static storage conditions: The best temperature for battery storage is -10°C~45°C; in case of storage for no use, the battery must be recharged and discharged once about every 1 month, and then stored in full voltage state. Please do not put the battery in fire or heat up the battery, and please do not store the battery in high-temperature environment;
- Charging: The battery must be charged with a dedicated lithium battery charger. Do not charge the battery below 0°C, and do not use batteries, power supplies, and chargers that are not standard.

Precautions for operational environment

- The operating temperature of BUNKERPRO is -20°C~60°C; please do not use it in the environment where the temperature is lower than -20°C or higher than 60°C;

- The relative humidity requirements of BUNKERPRO's operational environment are: maximum 80%, minimum 30%; Please do not use it in an environment with corrosive and flammable gas or in an environment near flammable substances;
- Do not store it around heating elements such as heaters or large coiled resistors;
- Except for the specially customized version (customized with IP protection level), BUNKER PRO is not waterproof, so please do not use it in environments with rain, snow, or standing water;
- It is recommended that the altitude of the operational environment should not exceed 1000M;
- It is recommended that the temperature difference between day and night in the operational environment should not exceed 25°C;
- Regularly inspect and maintain the track tension wheel.

Precautions for electrical external

- The current of the rear extension power supply should not exceed 10A, and the total power should not exceed 480W;

Safety precautions

- In case of any doubts during use, please follow related instruction manual or consult related technical personnel;
- Before use, pay attention to field condition, and avoid mis-operation that will cause personnel safety problem;
- In case of emergencies, press down the emergency stop button and power off the equipment;
- Without technical support and permission, please do not personally modify the internal equipment structure.

Other precautions

- Do not drop or put the vehicle upside down when carrying and setting up;
- For non-professionals, please do not disassemble the vehicle without permission.

CONTENTS

CONTENTS

Document version

Important Safety Information

Attention

CONTENTS

1 Introduction to BUNKERPRO

- 1.1 Product list
- 1.2 Tech specifications
- 1.3 Requirement for development

2 The Basics

- 2.1 Instructions on electrical interfaces
- 2.2 Instructions on remote control
- 2.3 Instructions on control demands and movements

3 Use and Development

- 3.1 Use and operation
- 3.2 Charging
 - 3.3.2 CAN cable connection
 - 3.3.3 Realization of CAN command control
- 3.4 Firmware upgrade
- 3.5 BUNKERPRO ROS Package Use Example

4 Q&A

5 Product Dimensions

- 5.1 Illustration diagram of product dimensions
- 5.2 Illustration diagram of top extended support dimensions

1 Introduction to BUNKERPRO

BUNKERPRO is a tracked chassis vehicle for all-round industry applications. It has the characteristics of simple and sensitive operation, large development space, suitable for

development and application in a variety of fields, independent suspension system, heavy-duty shock absorption, strong climbing ability, and being able to climb stairs. It can be used for the development of special robots such as robots for inspection and exploration, rescue and EOD, special shooting, special transportation, etc., to solve robot movement solutions.

1.1 Product list

Name	Quantity
BUNKER PRO Robot Body	x1
Battery Charger(AC 220V)	x1
Aviation male plug (4-Pin)	x1
FS remote control transmitter(Optional)	x1
USB to CAN communication module	x1

1.2 Tech specifications

Parameter Types	Items	Values
Mechanical specifications	L × W × H (mm)	1064*845*473
	Wheelbase (mm)	-
	Front/rear wheel base (mm)	-
	Chassis height	120
	Track width	150
	Curb weight (kg)	180
	Battery Type	Lithium battery

	Battery parameters	60AH
	Power drive motor	2×1500W Brushless servo motor
	Steering drive motor	-
	Parking mode	-
	Steering	Track type differential steering
	Suspension form	Christie suspension + Matilda four-wheel balance suspension
	Steering motor reduction ratio	-
	Steering motor encoder	-
	Drive motor reduction ratio	1: 7.5
	Drive motor sensor	Photoelectric increment 2500
Performance parameters	IP Grade	IP22
	Maximum speed (km/h)	1.7m/s
	Minimum turning radius (mm)	Can turn in place
	Maximum gradeability (°)	30°
	Maximum obstacle crossing	180
	Ground clearance (mm)	740
	Maximum battery life (h)	8
	Maximum distance (km)	15KM
	Charging time (h)	4.5
	Working temperature (°C)	-10~60°C

Control	Control mode	Remote control Control Command control mode
	RC transmitter	2.4G/extreme distance 200M
	System interface	CAN

1.3 Requirement for development

BUNKERPRO is equipped with FS remote control at the factory, and users can control the BUNKERPRO mobile robot chassis through remote control to complete the movement and rotation operations; BUNKERPRO is equipped with CAN interface, and users can carry out secondary development through it.

2 The Basics

This section will give a basic introduction to the BUNKERPRO mobile robot chassis, so that users and developers have a basic understanding of the BUNKERPRO chassis.

2.1 Instructions on electrical interfaces

The rear electrical interfaces are shown in Figure 2.1, where Q1 is the CAN and 48V power aviation interface, Q2 is the power switch, Q3 is the charging interface, Q4 is the antenna, Q5 and Q6 are respectively the driver debugging interface and the main control debugging interface (not open to the outside), and Q7 is the power display interaction.

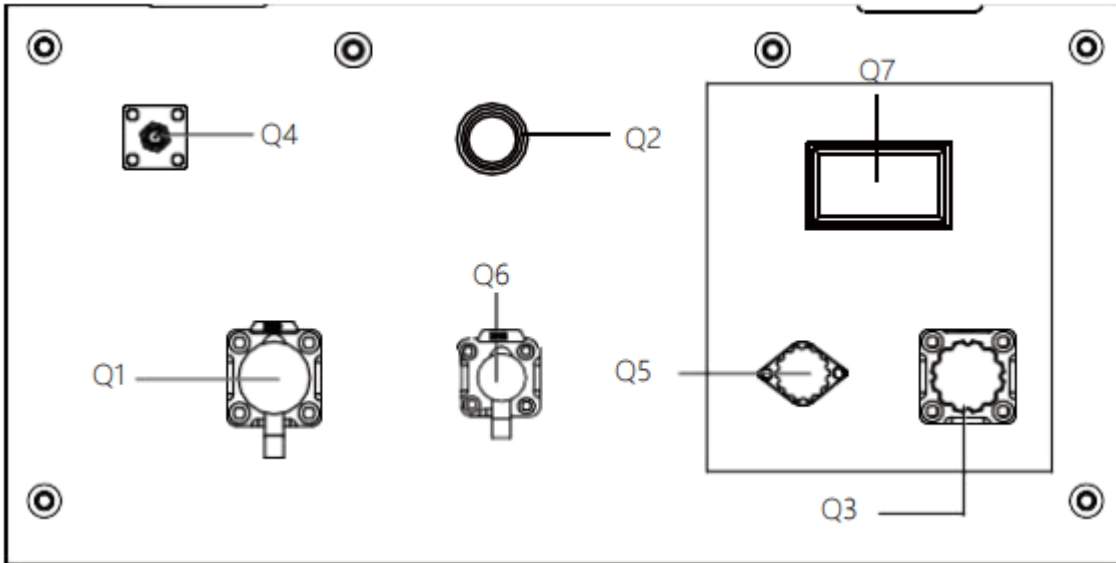
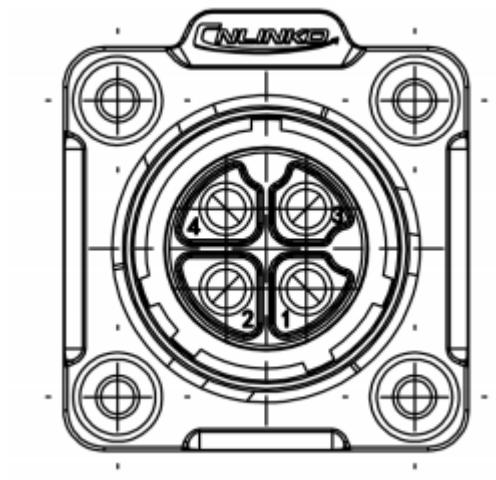

Figure 2.1 Rear Electrical Interfaces

The definition of Q1's communication and power interface is shown in Figure 2-2.



Pin No.	Pin Type	Function and Definition	Remarks
1	Power	VCC	Positive power supply, voltage range 46~54V, maximum current 10A
2	Power	GND	Negative power supply
3	CAN	CAN_H	CAN bus high
4	CAN	CAN_L	CAN bus low

Figure 2.2 Pin Definition of the Rear Aviation Extension Interface

2.2 Instructions on remote control

Remote control is an optional accessory for BUNKER PRO products. Customers can choose according to actual needs. Using the remote control can easily control the BUNKER PRO universal robot chassis. In this product, we use the left-hand throttle design. Its definition and functions can be referred to Figure 2.3. The functions of the buttons are defined as: SWA, SWB, SWC, SWD. SWD is not activated yet, among them SWB is the control mode selection button, dialed to the top is the command control mode, dialed to the middle is the remote control mode, S1 is the throttle button, controls the BUNKER PRO to move forward and backward; S2 controls the rotation, and POWER is the power supply Buttons, press and hold them at the same time to turn on. It should be noted that when the remote control is turned on, SWA, SWB, SWC, and SWD all need to be at the top.



Figure 2.3 Schematic diagram of the FS remote control buttons

Remote control interface description:

Bunker : model

Vol: battery voltage

Car: chassis status

Batt: Chassis power percentage

P: Park

Remoter: remote control battery level

Fault Code: Error information (Represents byte [5] in 211 frame)

2.3 Instructions on control demands and movements

We set up a coordinate reference system for ground mobile vehicle according to the ISO 8855 standard as shown in Figure 2.4.

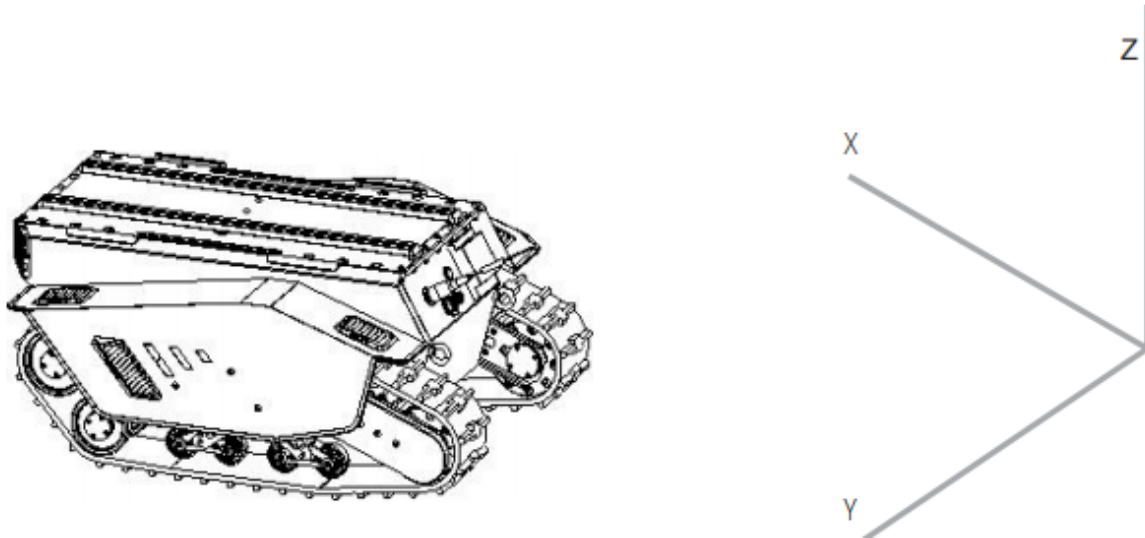

Figure 2.4 Schematic Diagram of Reference Coordinate System for Vehicle Body

As shown in Figure 2.4, the vehicle body of BUNKERPRO is parallel to the X axis of the established reference coordinate system.

In the remote control mode, push the remote controller rocker S1 forward to move in the positive direction of X, push S1 backward to move in the negative direction of X. When pushed to the minimum value, the movement speed in the negative direction of the X-axis is the maximum. The car body rotates from the positive direction of the X-axis to the negative direction of the Y-axis. When S2 is pushed to the left to the maximum value, the counterclockwise rotation linear speed is the maximum. When S2 is pushed to the right to the maximum value, the clockwise rotation linear motion is the maximum speed. In the control command mode, the positive value of the linear speed means moving in the positive direction of the X-axis, and the negative value of the linear speed means moving in the negative direction of the X-axis. The negative value of angular velocity means that the car body moves from the positive direction of the X-axis to the negative direction of the Y-axis.

3 Use and Development

This section mainly introduces the basic operation and use of the BUNKERPRO platform, and how to carry out the secondary development of the vehicle body through the external CAN interface and the CAN bus protocol.

3.1 Use and operation

Check

- Check the condition of the vehicle body. Check if the vehicle body has obvious abnormalities; if so, please contact after-sales support;
- When using for the first time, confirm whether Q2 (power switch) in the rear electrical panel is pressed; if it is not pressed, please press it and release it, then it is in the released state.

Startup

- Press the power switch (Q2 in the electrical panel); under normal circumstances, the light of the power switch will light up, and the voltmeter will display the battery voltage normally;
- Check the battery voltage. If the voltage is greater than 48V, it means the battery voltage is normal. If the voltage is lower than 48V, please charge; when the voltage is lower than 46V, BUNKERPRO cannot move normally.

Shutdown

- Press the power switch to cut off the power;

Basic operating procedures of remote control

- After starting the BUNKERPRO robot chassis normally, start the remote control and select the remote control mode to control the movement of the BUNKER PRO platform through the remote control.

3.2 Charging

BUNKERPRO is equipped with a standard charger by default, which can meet the charging needs of customers. **The specific operating procedures of charging are as follows:**

- Make sure that the BUNKERPRO chassis is in a shutdown state. Before charging, please make sure that Q2 (power switch) in the rear electrical console is turned off; insert the plug of the charger into the Q3 charging interface in the rear electrical control panel;
- Connect the charger to the power supply and turn on the charger switch to enter the charging state.
- When charging by default, there is no indicator light on the chassis. Whether it is charging or not depends on the status indicator of the charger.

3.3 Development

BUNKERPRO provides a CAN interface for the user's development, and the user can control the vehicle body through this interface.

The CAN communication standard in BUNKERPRO adopts the CAN2.0B standard; the communication baud rate is 500K, and the message format adopts the MOTOROLA format. The linear velocity of the movement and the angular velocity of the rotation of the chassis can be controlled through the external CAN bus interface; BUNKERPRO will feedback the current movement status information and the status information of the BUNKERPRO chassis in real time.

The protocol includes system status feedback frame, movement control feedback frame, and control frame. The content of the protocol is as follows:

The system status feedback command includes the current vehicle body status feedback, control status feedback, battery voltage feedback, and fault feedback. The content of the protocol is shown in Table 3.1.

Table 3.1 Feedback Frame of BUNKERPRO Chassis System Status

Command Name	System status feedback instruction			
Sending node	Receiving node	ID	Cycle (ms)	Receive timeout (ms)
Steer-by-wire chassis	Decision-making control unit	0x211	200ms	None
Data length	0x08			
Position	Function	Data type	Description	
byte [0]	Current status of vehicle body	unsigned int8	0x00 System in normal condition 0x01 Emergency stop mode 0x02 System exception	
byte [1]	Mode control	unsigned int8	0x00 Standby mode 0x01 CAN command control mode	

			0x03 Remote control mode
byte [2]	The battery voltage is 8 bits higher	unsigned int16	Actual voltage × 10 (with an accuracy of 0.1V)
byte [3]	The battery voltage is eight bits lower		
byte [4]	Reserved	-	0x0
byte [5]	Failure information	unsigned int8	Refer to [Description of Fault Information]
byte [6]	Reserved	-	0X00
byte [7]	Count check (count)	unsigned int8	0~255 cycle count; every time an instruction is sent, the count will increase once

Table 3.2 Description of Fault Information

Description of Fault Information		
Byte	Bit	Meaning
byte [5]	bit [0]	Battery undervoltage fault
	bit [1]	Battery undervoltage warning
	bit [2]	Remote control disconnection protection (0: normal, 1: remote control disconnection)
	bit [3]	No.1 motor communication failure (0: No failure 1: Failure)
	bit [4]	No.2 motor communication failure (0: No failure 1: Failure)
	bit [5]	Reserved, default 0

	bit [6]	Reserved, default 0
	bit [7]	Reserved, default 0

The command of movement control feedback frame includes the feedback of current linear velocity and angular velocity of moving vehicle body. The specific protocol content is shown in Table 3.3.

Table 3.3 Movement Control Feedback Frame

Command Name	Movement Control Feedback Command			
Sending node	Receiving node	ID	Cycle (ms)	Receive timeout (ms)
Steer-by-wire chassis	Decision-making control unit	0x221	20ms	None
Data length	0x08			
Position	Function	Data type	Description	
byte [0]	8-bit high moving speed	signed int16	Actual speed × 1000 (with an accuracy of 0.001m/s)	
byte [1]	8-bit low moving speed			
byte [2]	8-bit high rotation speed	signed int16	Actual speed × 1000 (with an accuracy of 0.001rad/s)	
byte [3]	8-bit low rotation speed			
byte [4]	Reserved	-	0x00	
byte [5]	Reserved	-	0x00	
byte [6]	Reserved	-	0x00	

byte [7]	Reserved	-	0x00
----------	----------	---	------

The control frame includes linear velocity control opening, angular velocity control opening and check sum. The specific content of the protocol is shown in Table 3.4.

Table 3.4 Movement Control Frame

Command Name	Control Instruction			
Sending node	Receiving node	ID	Cycle (ms)	Receive timeout (ms)
Decision-making control unit	Chassis node	0x111	20ms	None
Data length	0x08			
Position	Function	Data type	Description	
byte [0]	8-bit high linear speed	signed int16	Moving speed of vehicle body , unit: mm/s, range [-1700,1700]	
byte [1]	8-bit low linear speed			
byte [2]	8-bit high angular velocity	signed int16	Angular velocity of vehicle body rotation, unit: 0.001rad/s, range [- 3140,3140]	
byte [3]	8-bit low angular velocity			
byte [4]	Reserved	-	0x00	
byte [5]	Reserved	-	0x00	
byte [6]	Reserved	-	0x00	
byte [7]	Reserved	-	0x00	

The mode setting frame is used to set the control interface of the terminal. The specific protocol content is shown in Table 3.5

Table 3.5 Control Mode Setting Frame

Command Name	Control Mode Setting Command			
Sending node	Receiving node	ID	Cycle (ms)	Receive timeout (ms)
Decision-making control unit	Chassis node	0x421	20ms	500ms
Data length	0x01			
Position	Function	Data type	Description	
byte [0]	CAN control enable	unsigned int8	0x00 Standby mode 0x01 CAN command mode enable	

Note [1] Description of control mode

When the remote control of BUNKERPRO is not powered on, the control mode is standby mode by default, and you need to switch it to command mode to send movement control command. If the remote control is turned on, the remote control has the highest authority and can shield the control of commands. When the remote control is switched to the command mode, it still needs to send the control mode setting command before responding to the speed command.

The status setting frame is used to clear system errors. The specific protocol content is shown in Table 3.6.

Table 3.6 Status Setting Frame

Command Name	Status Setting Command			
Sending node	Receiving node	ID	Cycle (ms)	Receive timeout (ms)
Decision-making control unit	Chassis node	0x441	None	None
Data length	0x01			

Position	Function	Data type	Description
byte [0]	Error clearing command	unsigned int8	0x00 clear all errors 0x01 Clear motor 1's error 0x02 Clear motor 2's error

Note 3: Sample data; the following data is for testing purposes only

1. The vehicle advances at a speed of 0.15/S

byte [0]	byte [1]	byte [2]	byte [3]	byte [4]	byte [5]	byte [6]	byte [7]
0x00	0x96	0x00	0x00	0x00	0x00	0x00	0x00

2. The vehicle rotates at 0.2RAD/S

byte [0]	byte [1]	byte [2]	byte [3]	byte [4]	byte [5]	byte [6]	byte [7]
0x00	0x00	0x00	0xc8	0x00	0x00	0x00	0x00

In addition to the chassis status information will be fed back, the chassis feedback information also includes motor data and sensor data.

Table 3.7 Motor Speed Current Position Information Feedback

Command Name	Motor Drive High Speed Information Feedback Frame			
Sending node	Receiving node	ID	Cycle (ms)	Receive timeout (ms)
Steer-by- wire chassis	Decision-making control unit	0x251~0x254	20ms	None
Data length	0x08			
Position	Function	Data type	Description	

byte [0]	8-bit high motor speed	signed int16	Current motor speed Unit RPM
byte [1]	8-bit low motor speed		
byte [2]	Reserved	-	0x00
byte [3]	8-bit low drive temperature	-	Unit 1°C
byte [4]	Reserved	-	0x00
byte [5]	Drive status	unsigned int8	See Table 3.9 for details
byte [6]	Reserved	-	0x00
byte [7]	Reserved	-	0x00

Table 3.8 Motor Temperature, Voltage and Status Information Feedback

Command Name	Motor Drive Low Speed Information Feedback Frame			
Sending node	Receiving node	ID	Cycle (ms)	Receive timeout (ms)
Steer-by-wire chassis	Decision-making control unit	0x261~0x264	None	None
Data length	0x08			
Position	Function	Data type	Description	
byte [0]	Reserved	-	Current motor speed Unit RPM	
byte [1]	Reserved	-		
byte [2]	8-bit high drive temperature	signed int16	Unit 1°C	

byte [3]	8-bit low drive temperature		
byte [4]	Reserved	-	0x00
byte [5]	Drive status	unsigned int8	See Table 3.9 for details
byte [6]	Reserved	-	0x00
byte [7]	Reserved	-	0x00

Table 3.9 Drive Status

Byte	Bit	Description
byte [5]	bit [0]	Whether the power supply voltage is too low (0:Normal 1:Too low)
	bit [1]	Whether the motor is overheated (0: Normal 1: Overheated)
	bit [2]	Reserved
	bit [3]	Reserved
	bit [4]	Reserved
	bit [5]	Reserved
	bit [6]	Reserved
	bit [7]	Reserved

Table 3.10 Odometer Feedback Frame

Command Name	Odometer Information Feedback Frame			
Sending node	Receiving node	ID	Cycle (ms)	Receive timeout (ms)

Steer-by- wire chassis	Decision-making control unit	0x311	20ms	None
Data length	0x08			
Position	Function	Data type	Description	
byte [0]	Highest bit of left wheel odometer	signed int32	Chassis left wheel odometer feedback Unit: mm	
byte [1]	Second-highest bit of left wheel odometer			
byte [2]	Second-lowest bit of left wheel odometer			
byte [3]	Lowest bit of left wheel odometer			
byte [4]	Highest bit of right wheel odometer	signed int32	Chassis right wheel odometer feedback Unit: mm	
byte [5]	Second-highest bit of right wheel odometer			
byte [6]	Second-lowest bit of right wheel odometer			
byte [7]	Lowest bit of right wheel odometer			

Table 3.11 Remote Control Information Feedback

Command Name	Remote Control Information Feedback Frame			
Sending node	Receiving node	ID	Cycle (ms)	Receive timeout (ms)
Steer-by- wire chassis	Decision-making control unit	0x241	20ms	None
Data length	0x08			
Position	Function	Data type	Description	
byte [0]	Remote control SW feedback	unsigned int8	bit[0-1]: SWA: 2-Up 3-Down bit[2-3]: SWB: 2-Up 1-Middle 3-Down bit[4-5]: SWC: 2-Up 1-Middle 3-Down bit[6-7]: SWD: 2-Up 3-Down	
byte [1]	Right lever left and right	signed int8	Range: [-100,100]	
byte [2]	Right lever up and down	signed int8	Range: [-100,100]	
byte [3]	Left lever up and down	signed int8	Range: [-100,100]	
byte [4]	Left lever left and right	signed int8	Range: [-100,100]	
byte [5]	Left knob VRA	signed int8	Range: [-100,100]	
byte [6]	Reserved	-	0x00	

byte [7]	Count check	unsigned int8	0-255 cycle count
----------	-------------	---------------	-------------------

3.3.2 CAN cable connection

BUNKERPRO is shipped with a aviation plug male connector as shown in Figure 3.2. The definition of the cable: yellow is CANH, blue is CANL, red is power positive, and black is power negative.

Note: In the current BUNKERPRO version, the external extension interface is only open to the rear interface. In this version, the power supply can provide a maximum current of 10A.



Figure 3.2 Schematic Diagram of Aviation Plug Male Connector

3.3.3 Realization of CAN command control

Start the BUNKERPRO mobile robot chassis normally, turn on the FS remote control, and then switch the control mode to command control, that is, turn the SWB mode selection of the FS remote control to the top. At this time, the BUNKERPRO chassis will accept the command from the CAN interface, and the host can also analyze the current status of the chassis through the real-time data fed back by the CAN bus at the same time. Refer to CAN communication protocol for specific protocol content.

3.4 Firmware upgrade

In order to facilitate users to upgrade the firmware version of BUNKER MINI 2.0 and bring to customers more perfect experience, BUNKER MINI 2.0 provides the hardware interface for firmware upgrade and the corresponding client software.

Upgrade Preparation

- Agilex CAN debugging module X 1
- Micro USB cable X 1
- BUNKER PRO chassis X 1
- A computer (WINDOWS OS (Operating System)) X 1

Upgrade Process

1. Plug in the USBTOCAN module on the computer, and then open the AgxCandoUpgradeToolV1.3_boxed.exe software (the sequence cannot be wrong, first open the software and then plug in the module, the device will not be recognized).
2. Click the Open Serial button, and then press the power button on the car body. If the connection is successful, the version information of the main control will be recognized, as shown in the figure.

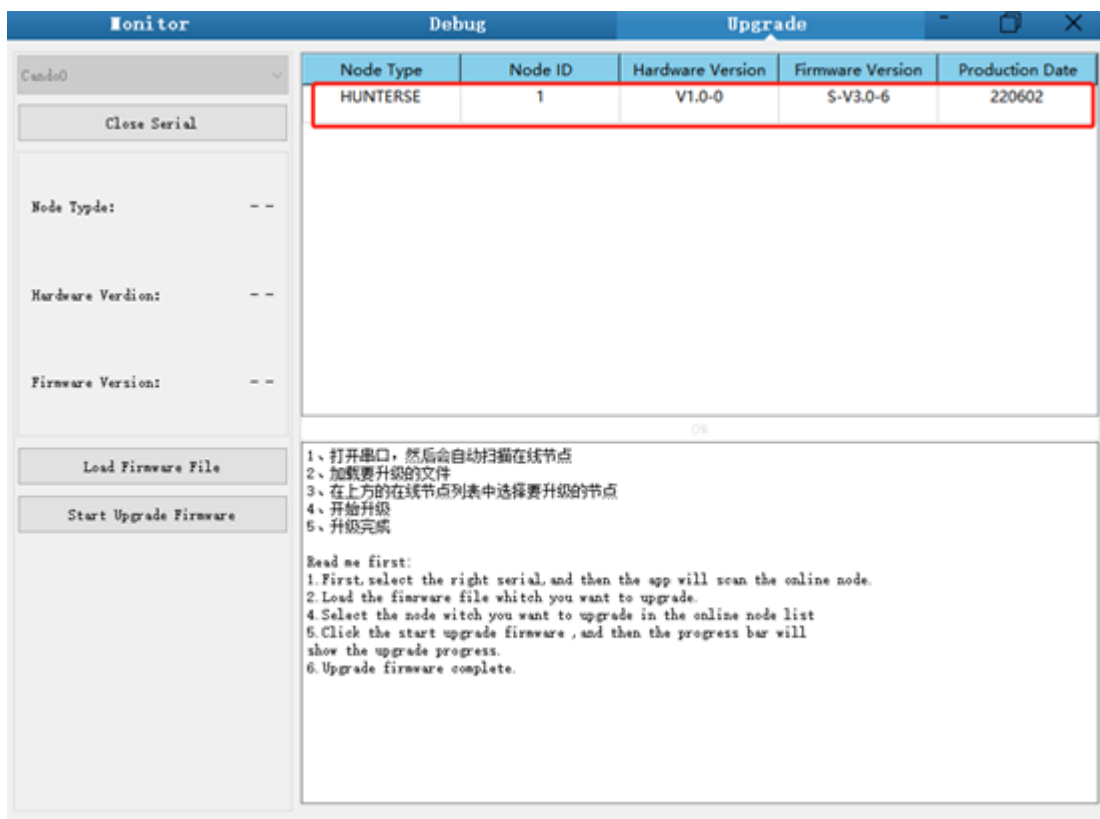

3. Click the Load Firmware File button to load the firmware to be upgraded. If the loading is successful, the firmware information will be obtained, as shown in the figure

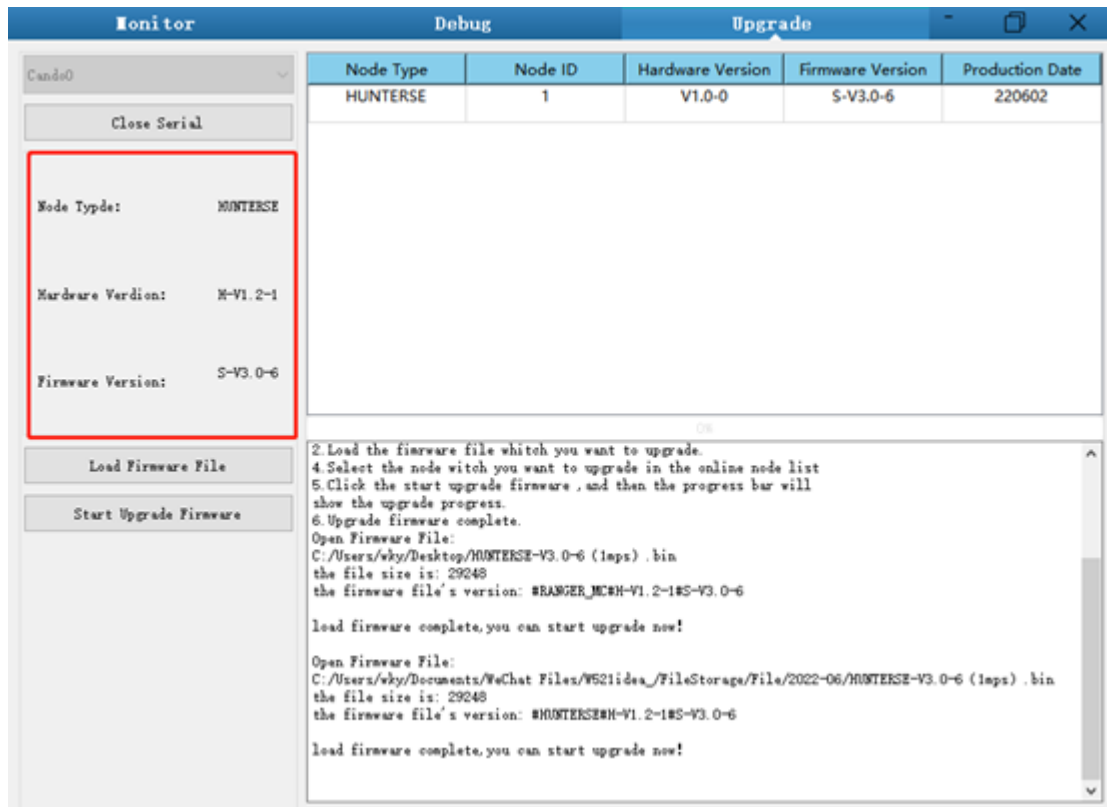

4. Click the node to be upgraded in the node list box, and then click Start Upgrade Firmware to start upgrading the firmware. After the upgrade is successful, a pop-up box will prompt.

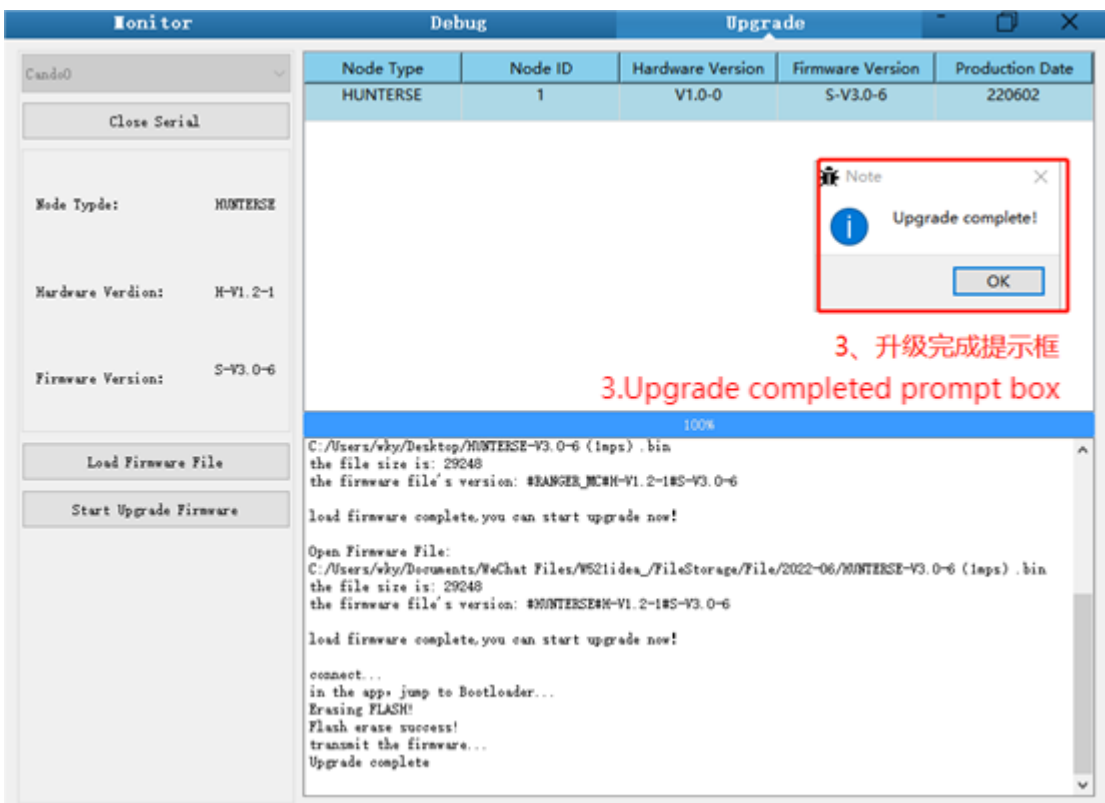
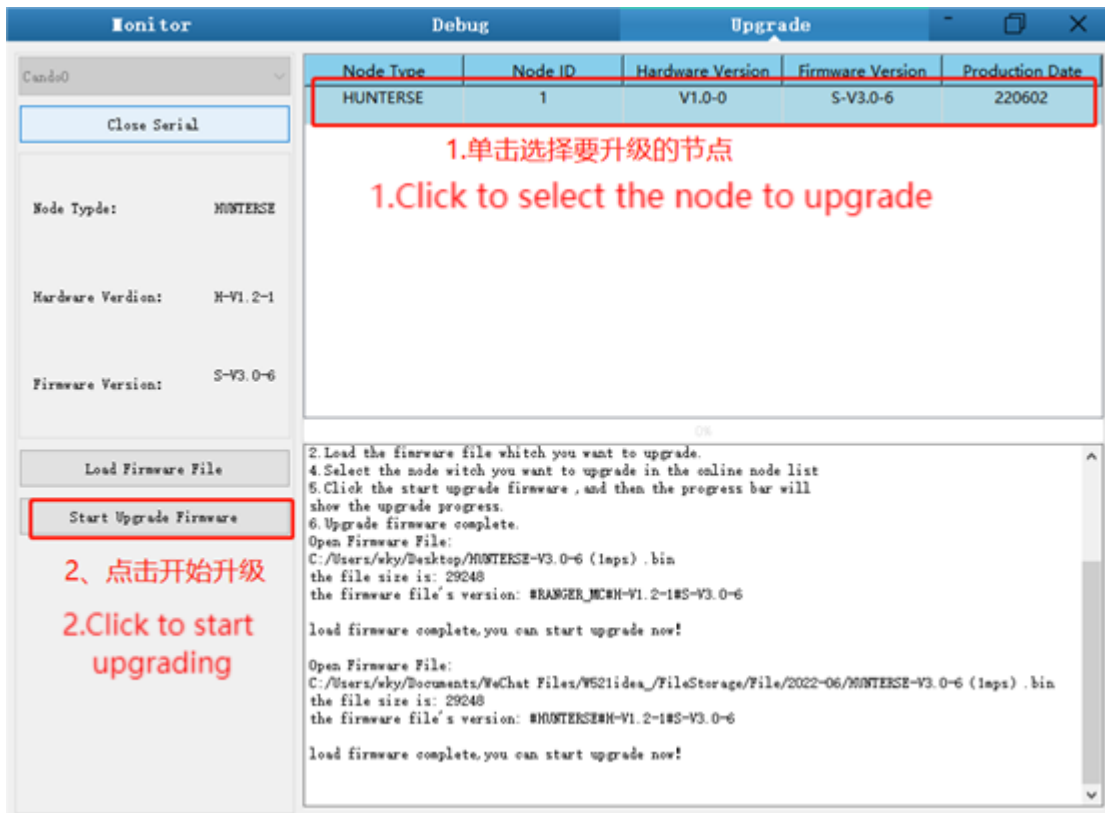

3.5 BUNKERPRO ROS Package Use Example

ROS provides some standard operating system services, such as hardware abstraction, low-level equipment control, implementation of common functions, inter-process message and data packet management. ROS is based on a graph architecture, so that processes of different nodes can receive, release, and aggregate various information (such as sensing, control, status, planning, etc.). Currently ROS mainly supports UBUNTU.

Development preparation

Hardware preparation

- CANlight can communication module X1
- Thinkpad E470 notebook X1
- AGILEX BUNKERPRO mobile robot chassis X1
- AGILEX BUNKERPRO supporting remote control FS-i6s X1
- AGILEX BUNKERPRO top aviation socket X1

Use example environment description

- Ubuntu 18.04
- ROS
- Git

Hardware connection and preparation

- Lead out the CAN cable of the BUNKERPRO top aviation plug or the tail plug, and connect CAN_H and CAN_L in the CAN cable to the CAN_TO_USB adapter respectively;
- Turn on the knob switch on the BUNKERPRO mobile robot chassis, and check whether the emergency stop switches on both sides are released;
- Connect the CAN_TO_USB to the usb interface of the notebook. The connection diagram is shown in Figure 3.4.

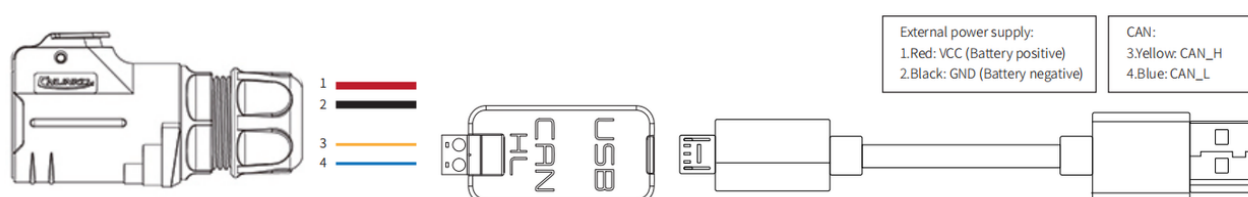

Figure 3.4 Schematic Diagram of CAN CABLE Connection

ROS installation and environment setting

For installation details, please refer to

<http://wiki.ros.org/kinetic/Installation/Ubuntu>

Test CANABLE hardware and CAN communication

Setting CAN-TO-USB adaptor

- Enable gs_usb kernel module

∨

复制代码

```
sudo modprobe gs_usb
```

- Setting 500k Baud rate and enable can-to-usb adaptor

∨

复制代码

```
sudo ip link set can0 up type can bitrate 500000
```

- If no error occurred in the previous steps, you should be able to use the command to view the can device immediately

∨

复制代码

```
ifconfig -a
```

- Install and use can-utils to test hardware

∨

复制代码

```
sudo apt install can-utils
```

- If the can-to-usb has been connected to the SCOUT 2.0 robot this time, and the car has been turned on, use the following commands to monitor the data from the SCOUT 2.0 chassis

∨

复制代码

```
candump can0
```

- Please refer to:

[1] https://github.com/agilexrobotics/agx_sdk

[2] https://wiki.rdu.im/_pages/Notes/Embedded-System/-Linux/can-bus-in-linux.html

AGILEX BUNKERPRO ROS PACKAGE download and compile

- Download ros dependent package

∨

复制代码

```
$ sudo apt install -y ros-$ROS_DISTRO-teleop-twist-keyboard
```

- Clone and compile bunker_ros source code

∨

复制代码

```
mkdir -p ~/catkin_ws/src
cd ~/catkin_ws/src
git clone https://github.com/agilexrobotics/ugv_sdk.git
git clone https://github.com/agilexrobotics/bunker_ros.git
cd ..
catkin_make
source devel/setup.bash
```

Reference source: https://github.com/agilexrobotics/bunker_ros

Start the ROS nodes

- Start the base node

∨

复制代码

```
roslaunch bunker_bringup bunker_robot_base.launch
```

- Start the keyboard remote operation node

∨

复制代码

```
roslaunch bunker_bringup bunker_teleop_keyboard.launch
```

Github ROS development package directory and usage instructions

*_base:: The core node for the chassis to send and receive hierarchical CAN messages. Based on the communication mechanism of ros, it can control the movement of the chassis and read the

status of the bunker through the topic.

*_msgs: Define the specific message format of the chassis status feedback topic

*_bringup: startup files for chassis nodes and keyboard control nodes, and scripts to enable the usb_to_can module

4 Q&A

Q: BUNKERPRO is started normally, but why does it not move when using the remote control to control the vehicle body?

A: First, confirm whether the power switch is pressed; and then, confirm whether the control mode selected through the mode selection switch on the upper left side of the remote control is correct.

Q: The BUNKERPRO remote control is normal; the chassis status and movement information feedback is normal; but why can't the vehicle body's control mode be switched, and why does the chassis not respond to the control frame protocol when the control frame protocol is issued?

A: Under normal circumstances, if BUNKERPRO can be controlled by the remote control, it means that the chassis movement control is normal; if it can receive the feedback frame of the chassis, it means that the CAN extension link is normal. Please check whether the command is switched to can control mode.

Q: When communicating through the CAN bus, the chassis feedback command is normal; but why does the vehicle not respond when issuing control?

A: BUNKERPRO has a communication protection mechanism inside. The chassis has a timeout protection mechanism when processing CAN control commands from the outside. Suppose that after the vehicle receives a frame of communication protocol, but it does not receive the next frame of control command for more than 500MS, it will enter the communication protection, and its speed is 0. Therefore, the commands from the host computer must be issued periodically.

5 Product Dimensions

5.1 Illustration diagram of product dimensions

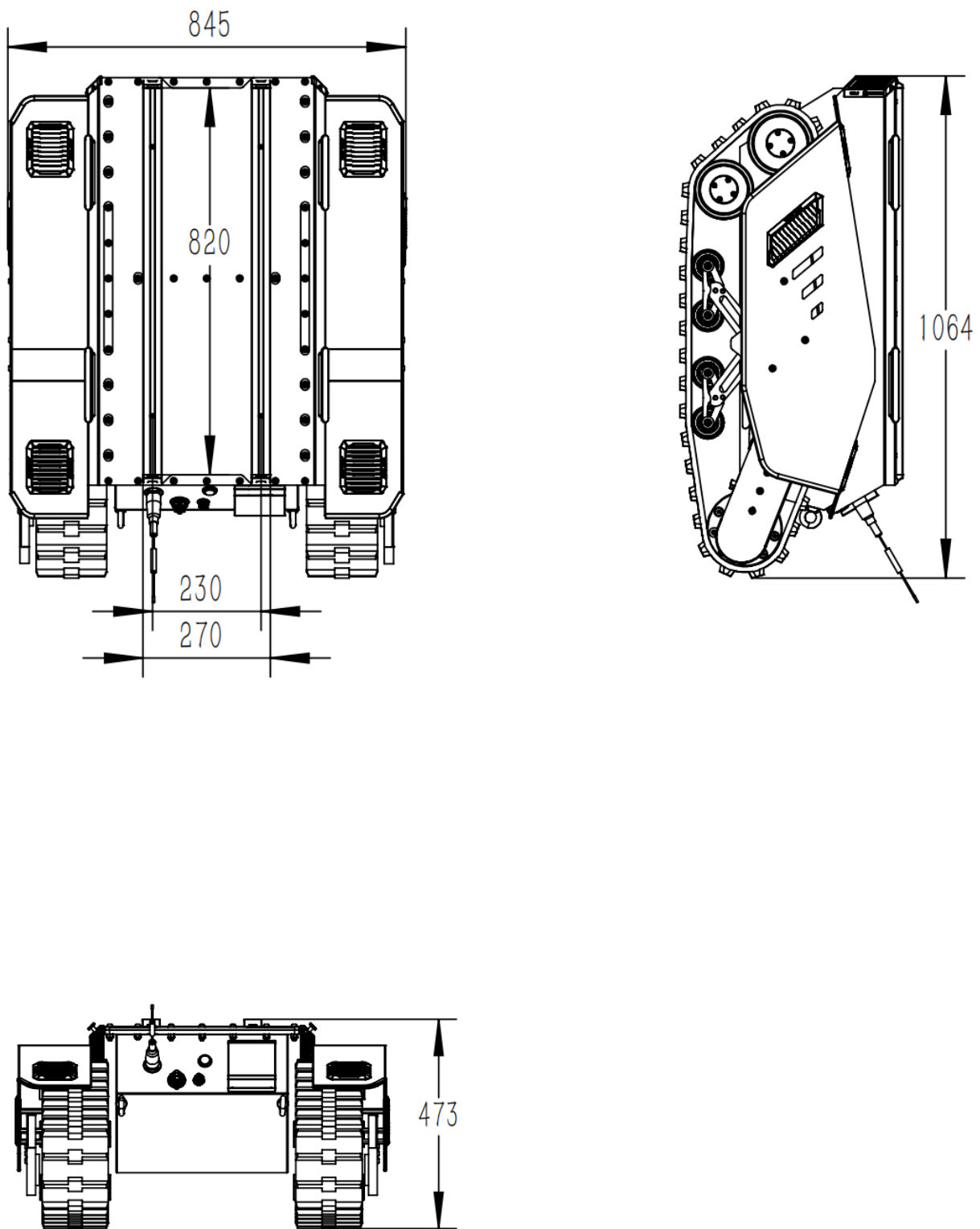

5.2 Illustration diagram of top extended support dimensions

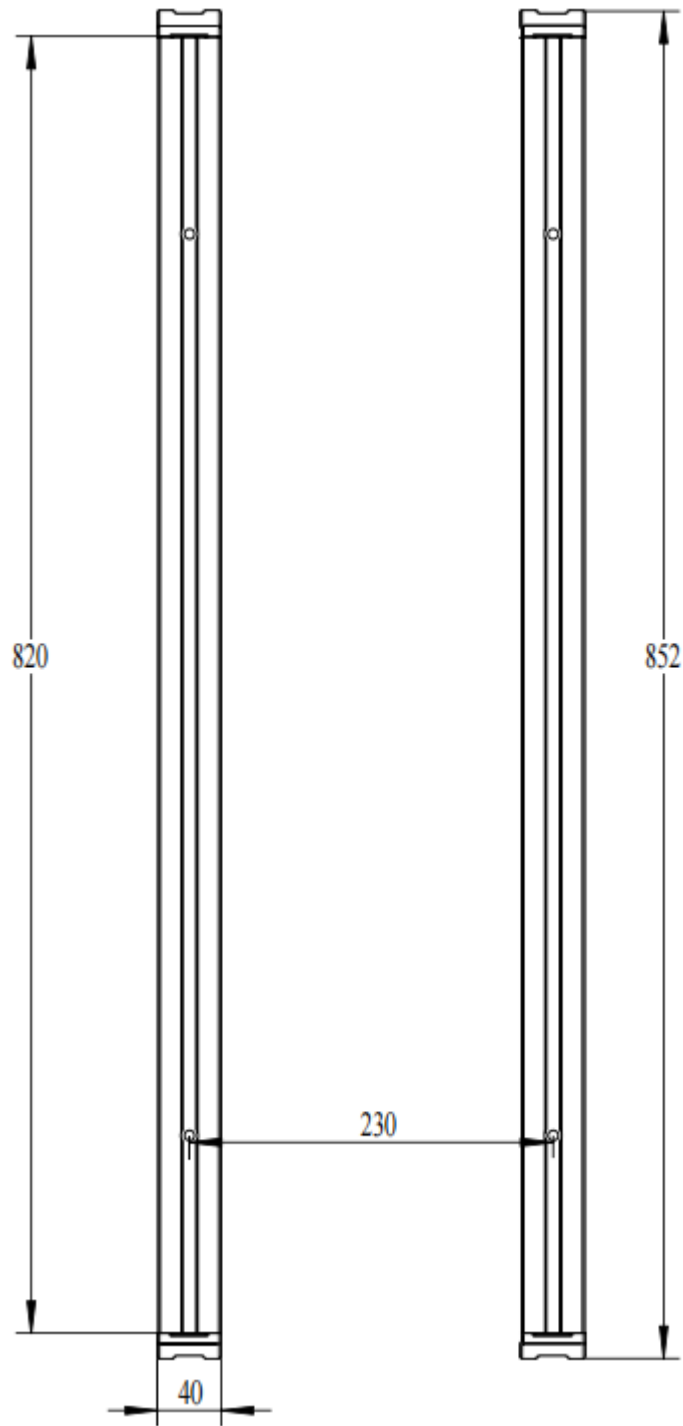

AGILE·X

松灵机器人(东莞)有限公司

WWW.AGILEX.AI

TEL:+86-0769-22892150

MOBILE:+86-19925374409

